

DATA[0:7]

CLK

Connect to DGND

AVcc C101 .1uF

6 DACEN 7 PD 10 REN 8 CS 9 CLK 13 D0 14 D1 15 D2 16 D3 17 D4 18 D5 19 D6 20 D7

U101
MAX5190

4 AGND 11 DGND 12 DGND 22 DGND

Maintain separate AGND, DGND
Connect at one point underneath device

2 OUTP

3 OUTN

24 REFO

23 REFR

C102 .1uF

Connect to AGND

T101
TCM8-1

Connect to AGND

J101

AVcc

4 U102

Vcc

GND

2

Connect to AGND

3 OUT

CLK

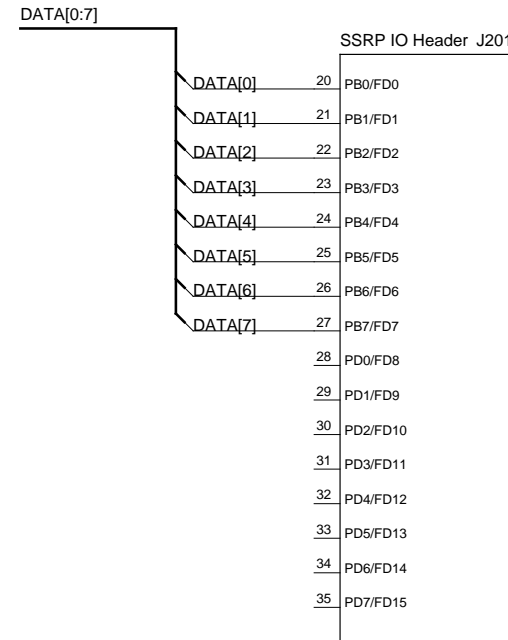
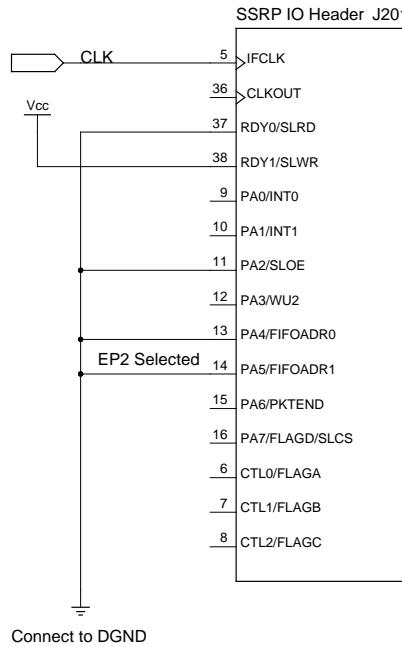
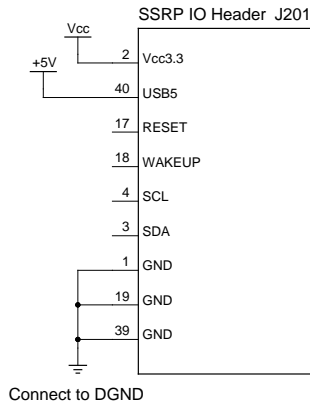
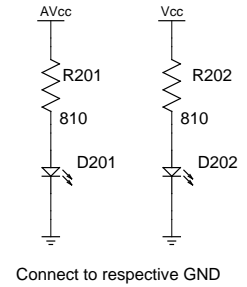
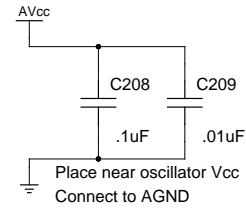
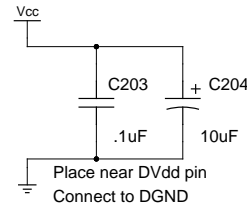
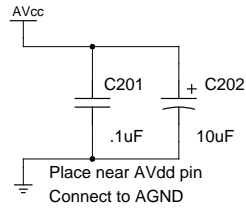
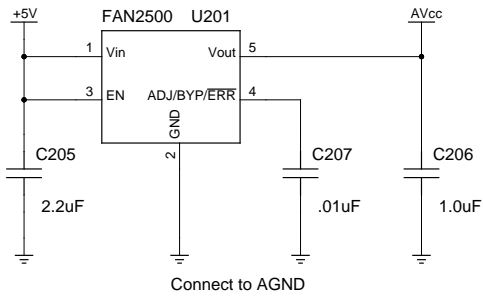
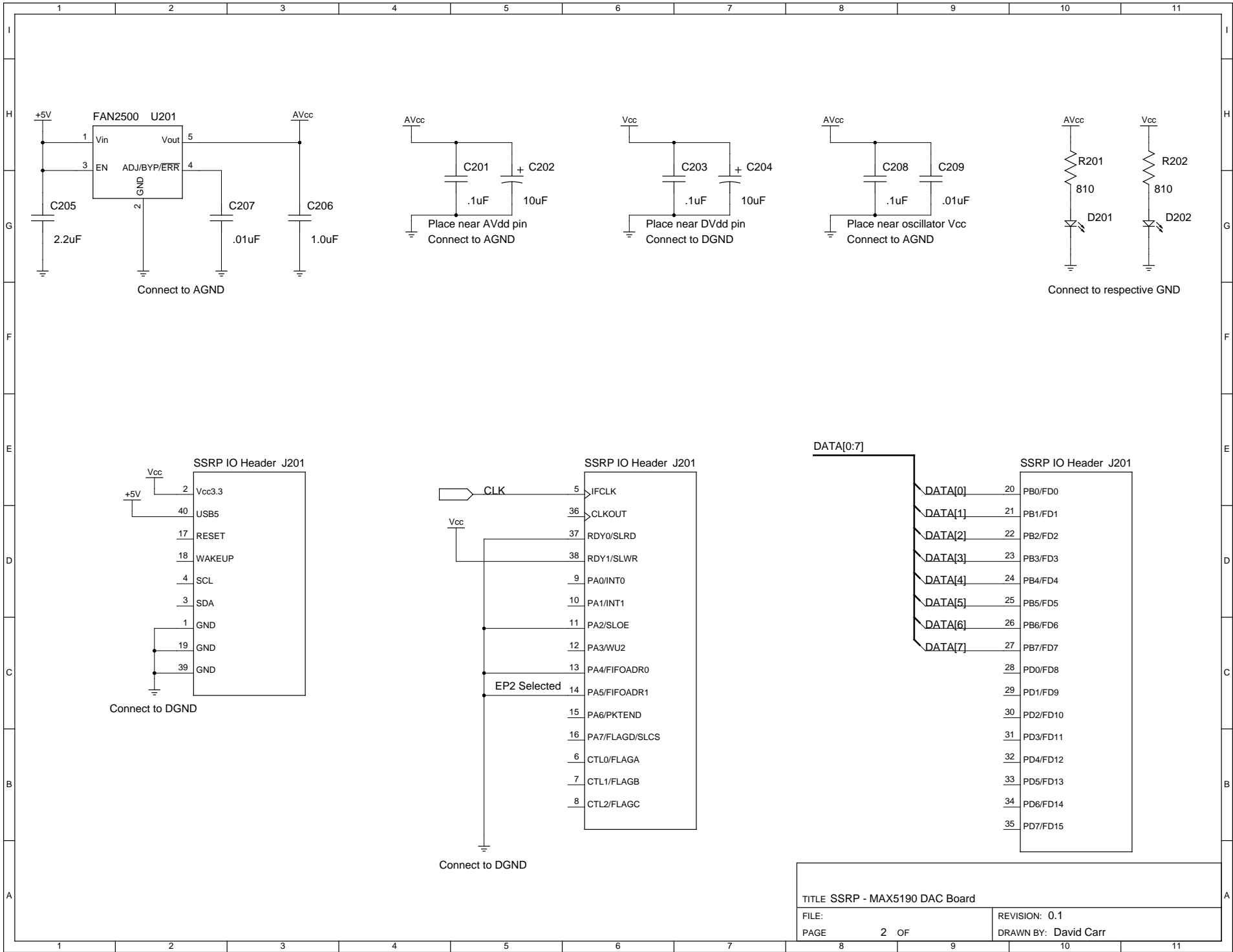

TITLE: SSRP - MAX5190 DAC Board
 FILE:
 PAGE: 2 OF
 REVISION: 0.1
 DRAWN BY: David Carr